

LPH-LD80-R-50-200-PM

Laser Process Head for advanced Material Processing



| Laser Material Processing |

Your product benefits:

- Optimized beam shaping for your application
- Perfect process tool for transmission welding of thermoplastics and soldering
- Safe process data transfer by ethernet communication
- Individual software package for data documentation and process control

Laser Process Head	Unit	Value	Unit	Value
Optical Data		Mechanical Data		
Max. laser power (cw)	W	350	Housing material	anodized aluminum
Wavelength range	nm	790 - 990	Dimensions (length x width x depth)	mm 153x158,2x89,5
Max. numerical aperture of fibre		0,23	Mounting threads (on both sides)	3 x M5
Max. fiber core diameter	µm	600	Fiber connector types	LD80
Transmission rate		≥ 90% (typ. 95 %)	Thermal Operation and Storage Conditions	
Collimation focal length	mm	50	Operation ambient temperature range	°C 5...40
Focussing focal length	mm	200	Max. operation relative humidity	non condensing
Working distance	mm	180 (± 10)	Storage temperature range	°C 20...50
Spot size FWHM with 200 µm fibre	µm	820	Storage max. relative humidity	non condensing
Spot size (90% PE*) with 200 µm fibre	µm	1200	Max. housing temperature in operation	°C 60
Spot size FWHM with 400 µm fibre	µm	1640		
Spot size (90% PE*) with 400 µm fibre	µm	2000		

* PE means power enclosed

Additional Features	Unit	Value	Unit	Value
Pyrometer Control Data		Power Monitoring Data		
Detection wavelength	nm	1.100 - 2.100	Wavelength range	nm 800 - 1.000
Temperature measurement range	°C	120 - 400	Sampling rate (standard)	kHz 1
Sampling rate (standard)	kHz	1	Operation temperature range	°C 15 - 40
Calibration standard type		black body	Measurement accuracy	% 0,2
Interfaces Data		Related Product		
Interface type		Ethernet	Process software	4PL Plus
Data cable type		CAT5		
Socket type		RJ45		
Communication protocol of laser driver		CAN-, Profi-Bus		

LPH-LD80-R-50-200-PM

Laser Process Head for advanced Material Processing

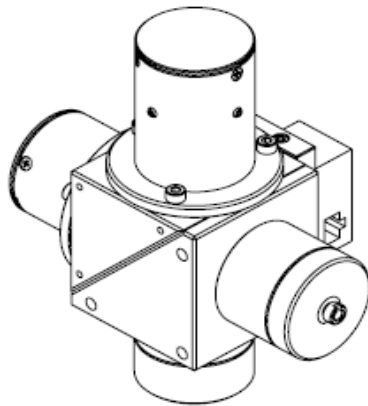
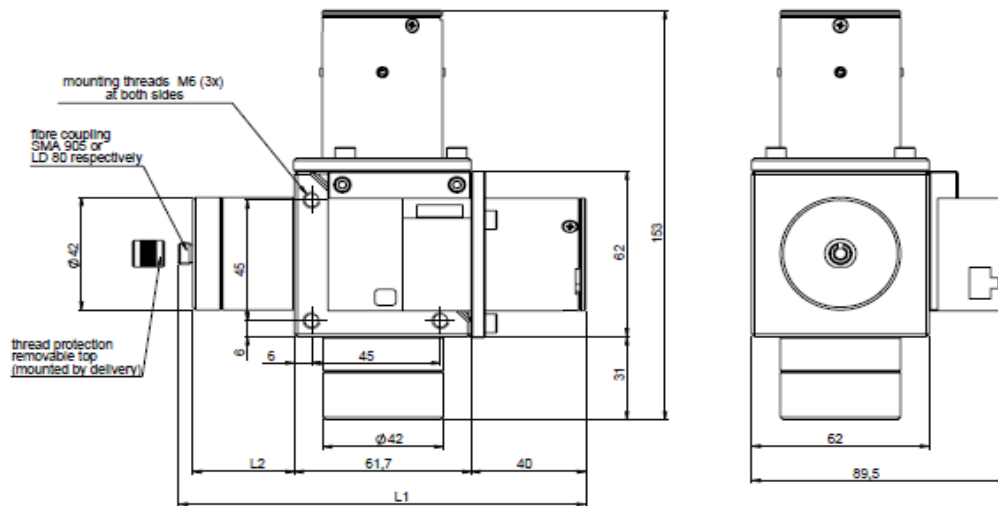

Model	L1 in mm	L2 in mm
Collimator 35	142,2	35,5
Collimator 50	158,2	51,5
Collimator 60	168,7	62,0

LPH-LD80-R-50-200

Copyright © 2012 LIMO GmbH. All rights reserved. All LIMO products are patent pending. Subject to change without notice.

Version May 15, 2015